

SIHI SINGLE & DOUBLE-ACTING OIL-FREE COMPRESSORS

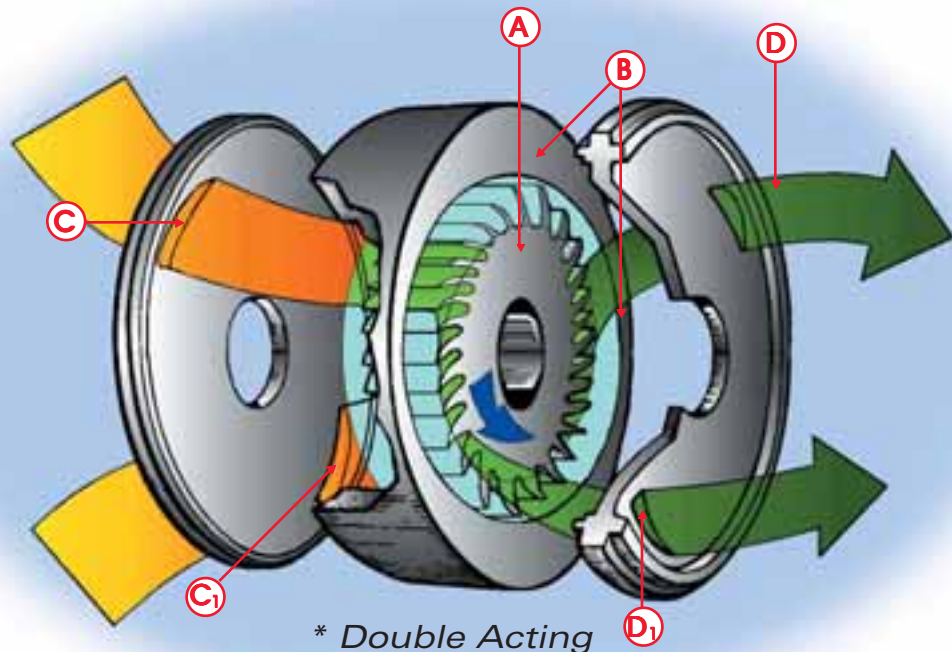

NOTE: The Single Acting Principle is shown in the Liquid Ring Vacuum Pump Brochure

In the SIHI double-acting compressor, a shaft-mounted impeller (A) coincides with the center line of an internally elliptical compressor body (B). As a result of centrifugal force, the service liquid assumes this elliptical shape. During each revolution of the impeller the blades are totally immersed in liquid at six and twelve o'clock, while all but the blade tips are exposed at three and nine o'clock. This design achieves a complete suction/compression cycle during each 180° rotation of the impeller.

Air or gas enters the compressor through the suction ports (C) & (C1), where the service liquid is receding to the root of the passing impeller blades. The gas is carried between the impeller blades and compressed by the service liquid. When fully submerged the gas is compressed and discharged through the discharge ports (D) & (D1).

During the compression cycle heat is imparted to the service liquid, which is continuously replaced with the cooled service liquid. The amount of coolant introduced is equal to the amount of service liquid discharged to the separator.

Since the points of highest compression are diametrically opposed with this double-acting compressor principle, minimizing this increases pump reliability and improves mechanical seal life.