

Product Catalog

CONSTRUCTION TYPE

The **SIHI** *dry* vacuum system has been especially developed for the use in chemical applications. It is based on the dry running twin screw principle without any lubricants or sealants required. Widely dimensioned clearances in the pumping chamber make the pump robust in the handling of particles and liquid.

The top vertical inlet to bottom discharge provides positive draining without any stagnant areas.

The cantilever bearings of the drive shafts allow the simple assembly of the pump casing without removal of the bearing. Simply unbolt and remove the pump casing and lift for internal inspection and cleaning

The shaft seals are a labyrinth design without internal contact and thus have no wear.

In contrast to conventional pumps both screw spindles are not mechanically but electronically synchronized. This innovative drive concept insures extremely low noise operation. The control and scheduled replacement of the gear oil is eliminated in the Sihi design.

SIHI *dry* M-Version



DESIGN

The flexibility of the modular system allows it to handle any process condition.

The innovative drive concept with the optional additional functions, **BASIC**, **DYNAMIC** and **CONTROL** regulate the speed at the exact operating point and allows the possibility to considerably reduce the power absorption. At the same time, the control valves for the purge of the pump, if necessary, is replaced by the vacuum system itself. Furthermore the intelligent electronics system offers the possibility to exactly monitor the important process data in order to insure a maximum of process safety and to recognize deviations in real time and to take appropriate measures.

FEATURES & BENEFITS

- No oil lubrication and sealing liquids in the pumping chamber or in the gear drive
- Problem-free handling of particles and liquids
- Rapid disassembly of the pumping chamber without bearing removal
- Shaft seal not in contact pumping media
- The bearings are not in contact with pumping media
- Noiseless electronic drive
- Compatibility of error detection with remote data transmission
- Protection overload

GENERAL TECHNICAL DATA for the SIHI^{dry} M- Version

Pump SIHI ^{dry}		M100	M160	M250	M400
Suction capacity		65 ACFM	95 ACFM	145 ACFM	235 ACFM
Final pressure		< 1 Torr	< 0.5 Torr	< 0.01 Torr	< 0.001 Torr
Speed Range		6,000 to 10,000 rpm	6,000 to 12,000 rpm		
Discharge Pressure		1.5 PSIG			
Discharge Temperature		< +275 °F			
Purge Gas Consumption		approx. 1.0 SCFM			
Power	MIN	3.4 HP	4.7 HP	2.7 HP	
Consumption	MAX	10 HP			
Cooling water T _{min}		+50 °F			
Cooling water T _{max}		+95 °F			
Sound level		< 54 dB(A)			
Weight		approx. 575 lbs			

PERFORMANCE RANGE for the SIHI^{dry} M- Version

Every operating point below the maximum characteristic curve displayed below is possible as from the drive variant **DYNAMIC** or **CONTROL** by the set point of speed.

**Suction Capacity of
SIHI^{dry} M-Version**

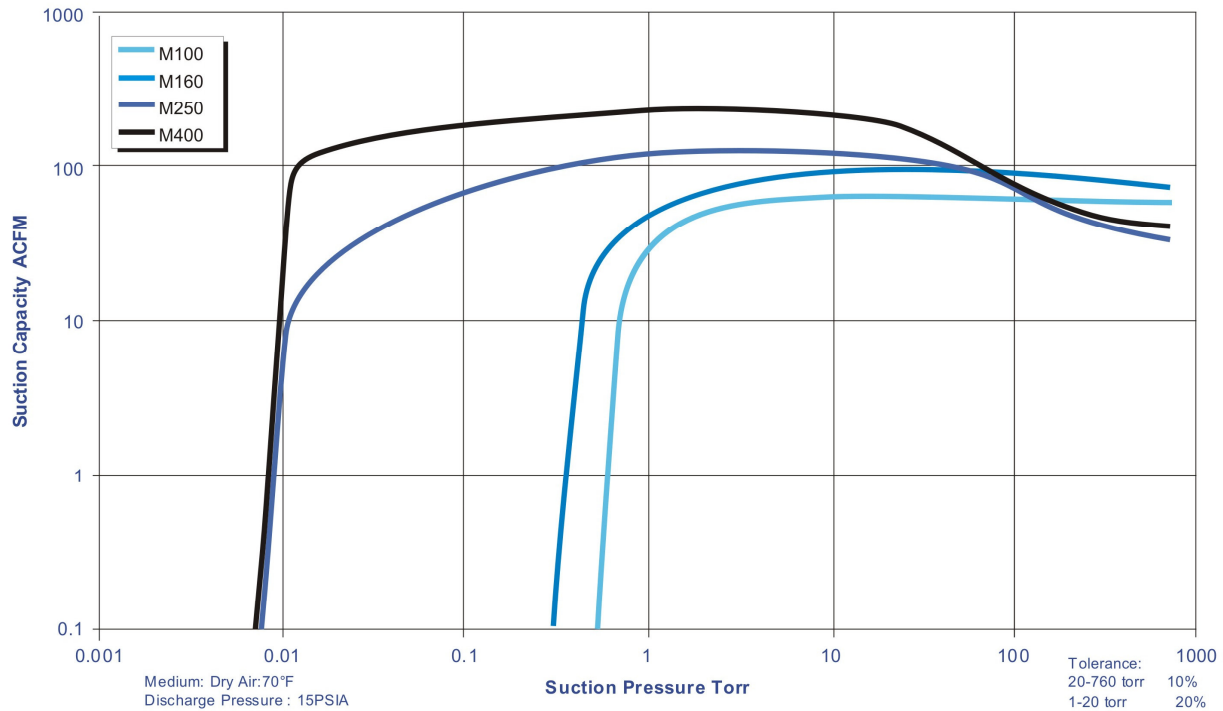

DIMENSION TABLE for the SIHI^{dry} M- Version

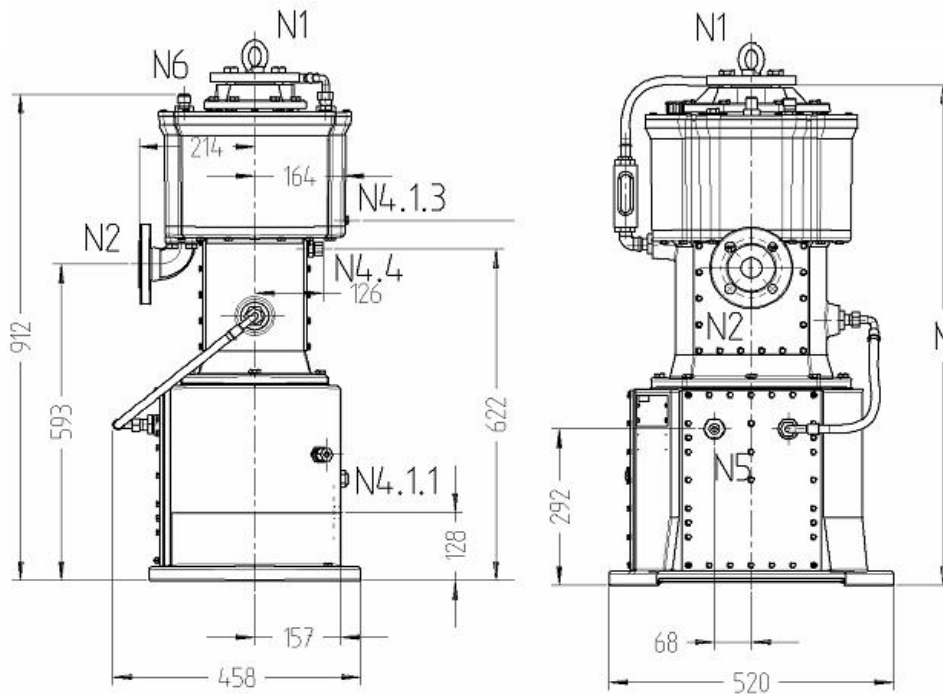

Height	N
• SIHI ^{dry} M100	
• SIHI ^{dry} M160	935
• SIHI ^{dry} M250	
• SIHI ^{dry} M400	990

Note: all dimensions in [mm]
25.4mm = 1 inch

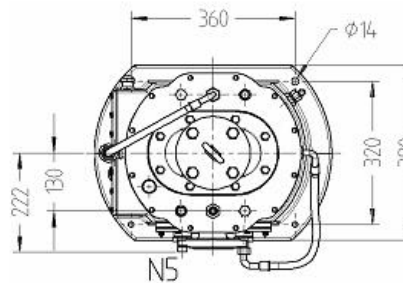

Connecting Dimensions / Sealing Surface					
	SIHI ^{dry}	M100	M160	M250	M400
Inlet (Adapting flange to NEMA provided)	N1	DN50 PN16 (4xM16) EN 1092-2 Form B (as per DIN 2501)		ISO F DN100 DIN28404 8xM8 DIN EN 1092-2 8xM8 / 4xM16	
Outlet (Adapting flange to NEMA provided)	N2	DN40 PN16 (4xØ18) EN 1092-2 Form B (as per DIN 2501)			
Purge Gas Inlet	N4.1.1	Ø12 mm			
Gas Dilution Inlet (Optional)	N4.1.3	Ø12 mm			
Shaft Seals Purge	N4.1.4	Ø12 mm			
Purge Gas Outlet	N4.4	Ø12 mm			
Cooling liquid inlet	N5	G ½" NPT threaded			
Cooling liquid outlet	N6	G ½" NPT threaded			

P&ID for the SIHI^{dry} M- Version

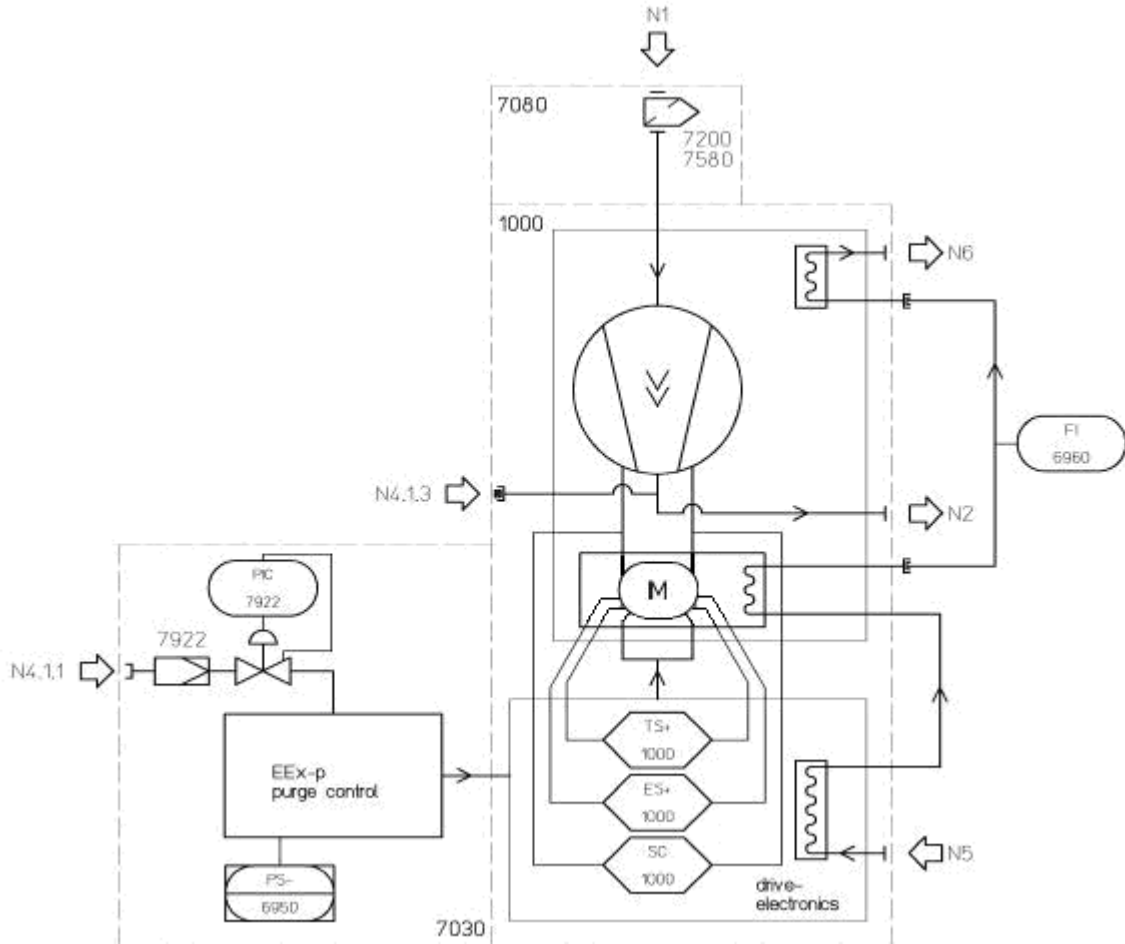

PUMP CONSTRUCTION for the SIHI^{dry} M- Version

Item	Components	Material	
16.20	Suction Side	Ductile Iron	GGG 40.3
16.00	Pumping Chamber	Stainless Steel	1.4122
10.30	Pumping Casing	Ductile Iron	GGG 40.3
10.40	Motor Casing	Ductile Iron	GGG 40.3
16.20	Casing Cover	Ductile Iron	1.0353
24.10	Screws	Stainless Steel	1.4122
35.00	Bearing Cartidge	Stainless Steel	1.4122
50.00	Throttle Rings	Ductile Iron	GG 25

